

Embedded Solutions



SATA III M.2 SSDs MTS800

Transcend's MTS800 with SATA III 6Gb/s interface and ultra compact dimensions makes it best suited to address the high-performance needs and strict size limitations of small form factor devices. This means it is perfect for use in today's modern ultrabooks, thin and light notebooks, and tablets. Built with the latest SATA III 6Gb/s specifications, and with a powerful controller and exceptional transfer speeds, the M.2 SSD easily handles everyday computing tasks as well as demanding multimedia applications.

Features

- Space-saving M.2 form factor (80mm) – ideal for mobile computing devices
- Supports DevSleep mode, which allows devices to completely shut down the SATA interface and conserve battery life unlike existing partial/slumber states
- DDR3 DRAM cache
- Supports S.M.A.R.T., TRIM and NCQ command
- RoHS compliant
- MLC NAND Flash
- Compliant with TCG Opal specifications (optional)

Ordering Information

16GB	TS16GMTS800
32GB	TS32GMTS800
64GB	TS64GMTS800
128GB	TS128GMTS800
256GB	TS256GMTS800
512GB	TS512GMTS800
1TB	TS1TGMTS800

Specifications

Appearance	Dimensions (Max.)	80.0 mm x 22.0 mm x 3.58 mm (3.15" x 0.87" x 0.14")
	Weight (Max.)	9 g (0.32 oz)
	Form Factor	M.2
	M.2 Type	2280-D2-B-M
Interface	Bus Interface	SATA III 6Gb/s
Storage	Flash Type	MLC NAND flash
	Capacity	16 GB/32 GB/64 GB/128 GB/256 GB/512 GB/1 TB
Operating Environment	Operating Voltage	3.3V±5%
	Operating Temperature	0°C (32°F) ~ 70°C (158°F)
	Storage Temperature	-40°C (-40°F) ~ 85°C (185°F)
	Humidity	0% ~ 95%
	Shock	1500 G, 0.5 ms, 3 axis
	Vibration (Operating)	3 G (peak-to-peak), 5 Hz ~ 800 Hz (frequency)
	Vibration (Non-operating)	5 G (peak-to-peak), 5 Hz ~ 800 Hz (frequency)
Power	Power Consumption (Operation)	2.64 watt(s)
	Power Consumption (Sleep)	0.41 watt(s)
Performance	Sequential Read/Write (ATTO, max.)	Read: 560 MB/s; write: 460 MB/s
	Sequential Read/Write (CrystalDiskMark, max.)	Read: 530 MB/s; write: 460 MB/s
	4K Random Read/Write (IOMeter, max.)	Read: 75,000 IOPS; write: 75,000 IOPS
	Mean Time Between Failures (MTBF)	1,500,000 hour(s)
	Terabytes Written (Max.)	2,360 TB
	Drive Writes Per Day (DWPD)	2.6 (3 yrs)
Warranty	Certificate	CE/FCC/BSMI
	Warranty	Three-year Limited Warranty
Note	<ul style="list-style-type: none"> • Speed may vary due to host hardware, software, usage, and storage capacity. • The workload used to rate DWPD may be different from your actual workload, which may vary due to host hardware, software, usage, and storage capacity. 	

Mechanical Dimensions

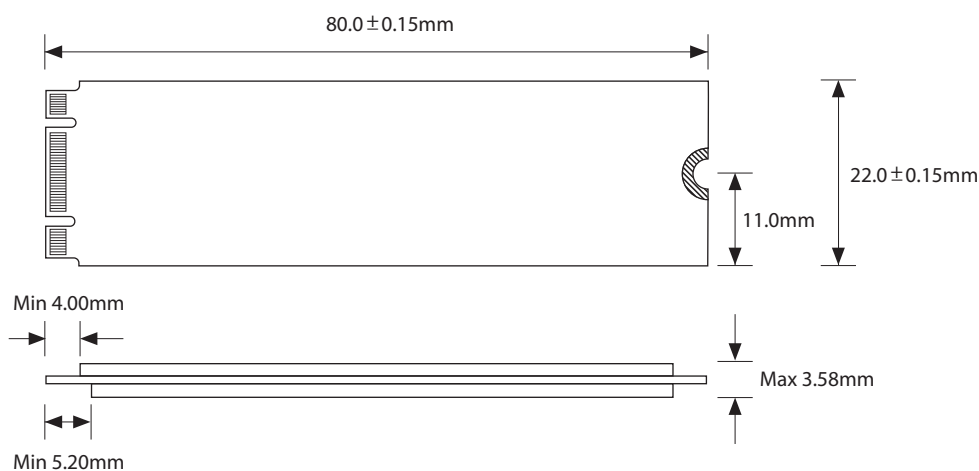

Product specifications are subject to change without notice. Pictures shown may differ from actual products. When used as a storage capacity unit, one terabyte (TB) = one trillion bytes. Total accessible capacity varies depending on operating environment. Due to the complexity and variety of industrial applications, Transcend cannot guarantee 100% compatibility with all platforms and under all scenarios. For special applications and environments, it is strongly suggested that you contact Transcend beforehand for clarification.



Please feel free to contact us with any special requests you might have.
Tel: +886-2-2792-8000 www.transcend-info.com