

Embedded Solutions



SD Cards

SD/SDHC100I

Transcend's Industrial Temp SD/SDHC100I cards combine the advantages of large storage capacity and industrial range (-40°C to 85°C) operating temperature flexibility, making them the best solution for tough industrial environments where performance and reliability are essential.

Hardware Features

- SLC NAND flash
- Promised operational reliability in a wide temperature range (from -40°C to 85°C)
- Electrostatic protection (ESD IEC 61000-4-2)
- Compliant with Speed Class 10
- Supports Transcend Scope Pro software

Firmware Features

- Built-in ECC (Error Correction Code) functionality
- Mechanical Write Protection switch for data security
- Supports Content Protection for Recorded Media (CPRM)
- Wear-Leveling

*Scope Pro is only available when used with the [RDF5](#) card reader.

Ordering Information

128MB	TS128MSD100I
256MB	TS256MSD100I
512MB	TS512MSD100I
1GB	TS1GSD100I
2GB	TS2GSD100I
4GB	TS4GSDHC100I

Specifications

Appearance	Dimensions	24 mm x 32 mm x 2.1 mm (0.94" x 1.26" x 0.08")
	Form Factor	SD flash card
Storage	Flash Type	SLC NAND flash
	Capacity	128 MB / 256 MB / 512 MB / 1 GB / 2 GB / 4 GB
Operating Environment	Operating Voltage	2.7V ~ 3.6V
	Drop Test	1.5m free fall
	Operating Temperature	Wide Temp. -40°C (-40°F) ~ 85°C (185°F)
	Storage Temperature	-40°C (-40°F) ~ 85°C (185°F)
	Humidity	0% ~ 95%
	Shock	Acceleration: 490 m/s ² (standard holding time: 11 ms, semi-sine wave, velocity change: 3.44 m/s)
	Vibration (Operating)	20 G (peak-to-peak), 20 Hz ~ 2,000 Hz (frequency)
Power	Power Consumption (Max.)	0.72 watt(s)
Performance	Read Speed (Max.)	up to 18.5 MB/s
	Write Speed (Max.)	up to 18.8 MB/s
	Terabytes Written (TBW)	up to 125 TBW
Warranty	Certificate	CE / FCC / UKCA
	Warranty	Three-year Limited Warranty

Mechanical Dimensions

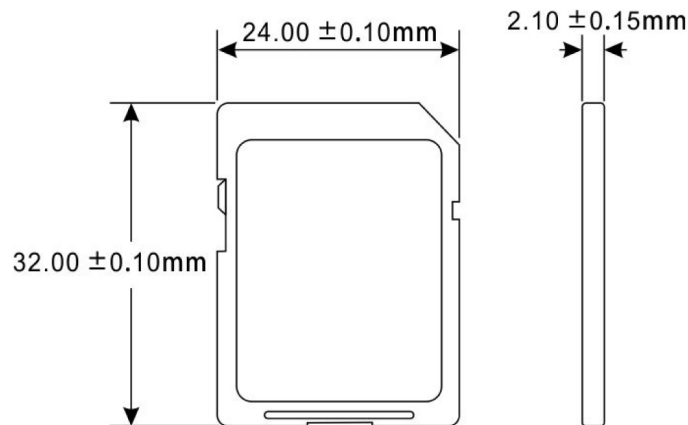

Product specifications are subject to change without notice. Pictures shown may differ from actual products. Total accessible capacity varies depending on operating environment. Due to the complexity and variety of industrial applications, Transcend cannot guarantee 100% compatibility with all platforms and under all scenarios. For special applications and environments, it is strongly suggested that you contact Transcend beforehand for clarification.