

Embedded Solutions

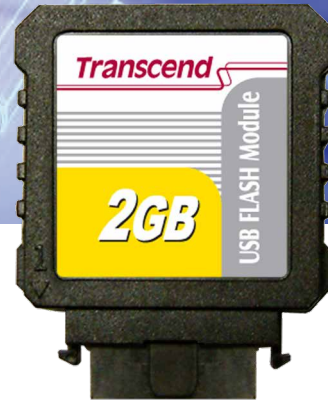

USB Flash Module

UFM-V

Vertical

Transcend's USB Flash modules are convenient, easy to implement solutions for expanding the memory capacity of industrial computers. These compact storage devices consume a minimal amount of power and feature a mechanical write protection switch. Due to their minimalist dimensions, these USB modules are suitable for use in small embedded systems.

Features

- Hi-Speed USB 2.0 compliant
- Supporting Hot-Swapping, True Plug and Play functionality
- Fully compatible with devices and Operating Systems (OS) that support the USB standard
- Low power consumption
- Fully compliant with open industry standards
- Write protection switch

Ordering Information

512MB	TS512MUFM-V
1GB	TS1GUFM-V
2GB	TS2GUFM-V

Specification

Appearance	Dimensions (Max.)	31.80 mm x 26.00 mm x 7.00 mm (1.25" x 1.02" x 0.28")
	Pin	10 pin
	Pitch	2.54mm (normal type)
Interface	Connection Interface	USB 2.0
Storage	Flash Type	SLC NAND flash
	Capacity	512 MB / 1 GB / 2 GB
Operating Environment	Operating Voltage	5V±10%
	Operating Temperature	0°C (32°F) ~ 70°C (158°F)
	Storage Temperature	-40°C (-40°F) ~ 85°C (185°F)
	Humidity	0% ~ 95%
	Shock	1500 G, 0.5 ms, 3 axis
	Vibration (Operating)	20 G (peak-to-peak), 20 Hz ~ 2,000 Hz (frequency)
Power	Power Consumption (Operation)	0.6 watt(s)
Performance*	Read Speed (Max.)	21 MB/s
	Write Speed (Max.)	13 MB/s
	Mean Time Between Failures (MTBF)	1,000,000 hour(s)
Warranty	Warranty	Three-year Limited Warranty
Note	* Speed may vary due to host hardware, software, usage, and storage capacity.	

Mechanical Specification

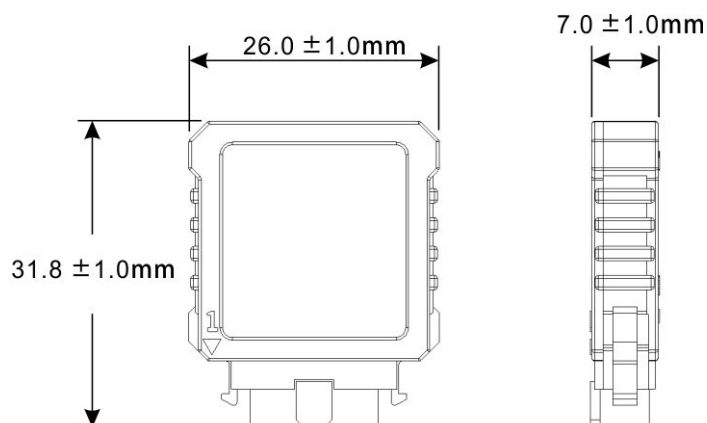

Product specifications are subject to change without notice. Pictures shown may differ from actual products. When used as a storage capacity unit, one terabyte (TB) = one trillion bytes. Total accessible capacity varies depending on operating environment. Due to the complexity and variety of industrial applications, Transcend cannot guarantee 100% compatibility with all platforms and under all scenarios. For special applications and environments, it is strongly suggested that you contact Transcend beforehand for clarification.



Please feel free to contact us with any special requests you might have.

Tel: +886-2-2792-8000 www.transcend-info.com