

Embedded Solutions



CompactFlash Cards CF200I

Built extra-rugged with excellent temperature flexibility and high performance, Transcend's CF200I Industrial Temp CF cards are specifically designed for industrial use and mission-critical applications.

Hardware Features

- Compliant with RoHS 2.0 standards
- Compliant with CompactFlash specification 4.1
- Intelligent Power Shield (IPS) to prevent data loss in the event of sudden power outage
- Durability: 10,000 insertion/removal cycles

Firmware Features

- Enhanced S.M.A.R.T. function for durability
- Security Command
- Wear-Leveling
- Static Data Refresh
- Early Retirement

Ordering Information

1GB	TS1GCF200I
2GB	TS2GCF200I
512MB	TS512MCF200I

Specifications

Appearance	Dimensions	42.8 mm x 36.4 mm x 3.3 mm (1.69" x 1.43" x 0.13")
	Pin Count	50 pin
	Form Factor	Compact flash card
Storage	Flash Type	SLC NAND flash
	Capacity	512 MB / 1 GB / 2 GB
Operating Environment	Operating Voltage	3.3V±5% 5V±10%
	Operating Temperature	-40°C (-40°F) ~ 85°C (185°F)
	Storage Temperature	-55°C (-67°F) ~ 100°C (212°F)
	Humidity	0% ~ 95%
	Shock	Acceleration: 490 m/s ² (standard holding time: 11 ms, semi-sine wave, velocity change: 3.44 m/s)
	Vibration (Operating)	20 G (peak-to-peak), 20 Hz ~ 2,000 Hz (frequency)
Power	Power Consumption (Max.)	0.23 watt(s)
Performance	Read Speed (Max.)	up to 29 MB/s
	Write Speed (Max.)	up to 10 MB/s
	Mean Time Between Failures (MTBF)	4,000,000 hour(s)
Warranty	Warranty	Three-year Limited Warranty

Mechanical Dimensions

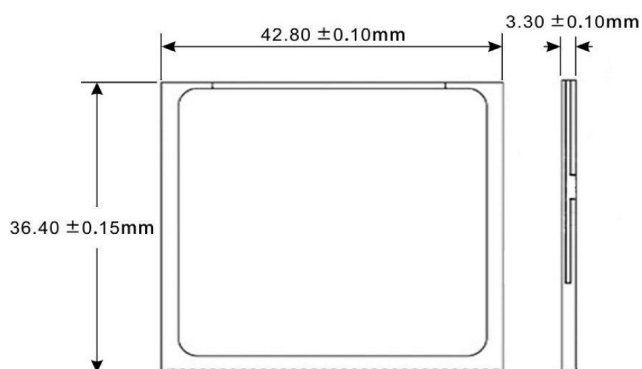

Product specifications are subject to change without notice. Pictures shown may differ from actual products. Total accessible capacity varies depending on operating environment. Due to the complexity and variety of industrial applications, Transcend cannot guarantee 100% compatibility with all platforms and under all scenarios. For special applications and environments, it is strongly suggested that you contact Transcend beforehand for clarification.