

**Embedded Solutions**



PCIe M.2 SSDs

# MTE712A & MTE712A-I

Transcend's M.2 SSD MTE712A is a self-encrypting drive (SED) that complies with the TCG Opal 2.0 standards. Data is protected using the hardware-based AES 256-bit encryption and LBA (Logical Block Address) sector-specific permissions.

The MTE712A features the 112-layer 3D NAND flash and the PCI Express (PCIe) Gen4 x4 interface, achieving never-before-seen transfer speeds. Its built-in DRAM cache allows faster random speeds while the 30µ" gold finger PCB, Corner Bond technology, and anti-sulfur resistor guarantee its reliability in harsh conditions. The MTE712A is fully tested in-house, operating stably in an extended operating temperature range (-20°C~75°C).

Transcend also offers the MTE712A-I with wide temperature (-40°C~ 85°C) capabilities to ensure sustained functionality, enhanced endurance and optimal reliability in mission-critical applications.

## Hardware Features

- Compliant with PCI Express specification 4.0
- Compliant with NVM Express specification 1.4
- PCIe Gen 4 x4 interface
- Endurance: 3K P/E cycles (Program/Erase cycles) guaranteed
- Anti-sulfur technology implemented to prevent sulfurization in the environment

## Firmware Features

- Dynamic thermal throttling
- Built-in LDPC ECC (Error Correction Code) functionality
- Supports S.M.A.R.T. function to conduct health monitoring, analysis, and reporting for storage devices
- Full drive encryption with Advanced Encryption Standard (AES)
- Compliant with TCG Opal specifications and IEEE 1667 standards

## Ordering Information

128GB	TS128GMTE712A TS128GMTE712A-I
256GB	TS256GMTE712A TS256GMTE712A-I
512GB	TS512GMTE712A TS512GMTE712A-I
1TB	TS1TMTE712A TS1TMTE712A-I
2TB	TS2TMTE712A TS2TMTE712A-I

\*Supports Microsoft® eDrive standard

## Specifications

<b>Appearance</b>	Dimensions	80 mm x 22 mm x 3.58 mm (3.15" x 0.87" x 0.14")
	Weight	9 g (0.32 oz)
	M.2 Type	2280-D2-M (Double-sided)
	Form Factor	M.2 2280
<b>Interface</b>	Bus Interface	NVMe PCIe Gen4 x4
<b>Storage</b>	Capacity	128 GB / 256 GB / 512 GB / 1 TB / 2 TB
	Flash Type	112-layer 3D NAND flash
<b>Operating Environment</b>	Operating Voltage	3.3V±5%
	Operating Temperature	Extended Temp. -20°C (-4°F) ~ 75°C (167°F)
		Wide Temp. -40°C (-40°F) ~ 85°C (185°F)
	Storage Temperature	-55°C (-67°F) ~ 85°C (185°F)
	Humidity	5% ~ 95%
	Shock	15 G, 11 ms, 3 axis
	Vibration (Operating)	20 G (peak-to-peak), 7 Hz ~ 2000 Hz (frequency)
<b>Power</b>	Power Consumption (Operation)	5.6 watt(s)
	Power Consumption (IDLE)	1.28 watt(s)
<b>Performance</b>	Sequential Read/Write (CrystalDiskMark)	Read: Up to 3,800 MB/s Write: Up to 3,200 MB/s
	4K Random Read/Write (IOmeter)	Read: Up to 350,000 IOPS Write: Up to 330,000 IOPS
	Mean Time Between Failures (MTBF)	3,000,000 hour(s)
	Terabytes Written (TBW)	Up to 4,000 TBW
	Drive Writes Per Day (DWPD)	1.99 (3 yrs)
<b>Warranty</b>	Certificate	CE / UKCA / FCC / BSMI
	Warranty	Three-year Limited Warranty

## Mechanical Dimensions

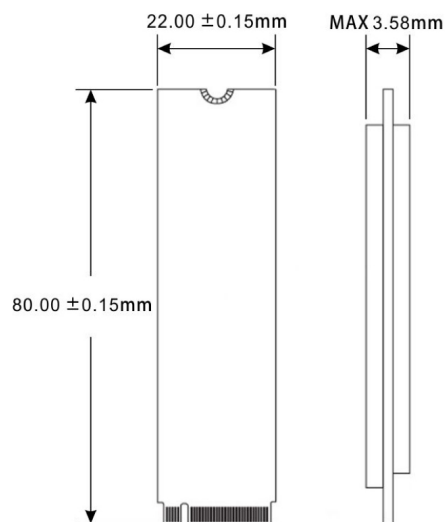

Product specifications are subject to change without notice. Pictures shown may differ from actual products. Total accessible capacity varies depending on operating environment. Due to the complexity and variety of industrial applications, Transcend cannot guarantee 100% compatibility with all platforms and under all scenarios. For special applications and environments, it is strongly suggested that you contact Transcend beforehand for clarification.