

## Embedded Solutions



# SATA III M.2 SSDs MTS600 & MTS600I

Transcend's MTS600 with SATA III 6Gb/s interface and ultra compact dimensions make it best suited to address the high-performance needs and strict size limitations of small form factor devices. This means it is perfect for use in today's modern ultrabooks, thin and light notebooks, and tablets. Built with the latest SATA III 6Gb/s specifications, and with a powerful controller and exceptional transfer speeds, the M.2 SSD easily handles everyday computing tasks as well as demanding multimedia applications.

Transcend also offers the MTS600I with wide temperature (-40°C ~ 85°C) capabilities to ensure sustained functionality, enhanced endurance and optimal reliability in mission-critical applications.

## Features

- Space-saving M.2 form factor (60mm) – ideal for mobile computing devices
- Wide-temperature model available: promised operational reliability in a wide temperature range (from -40°C ~ 85°C)
- DRAM cache
- Supports S.M.A.R.T., TRIM and NCQ command
- Compliant with RoHS 2.0 standards
- Power-saving DevSleep (Device Sleep) mode
- MLC NAND Flash

## Ordering Information

### Standard (0°C~ 70°C)

32GB	TS32GMTS600
64GB	TS64GMTS600
128GB	TS128GMTS600
256GB	TS256GMTS600
512GB	TS512GMTS600

### Wide Temp. (-40°C~ 85°C)

32GB	TS32GMTS600I
64GB	TS64GMTS600I
128GB	TS128GMTS600I
256GB	TS256GMTS600I
512GB	TS512GMTS600I

## Specifications

Appearance	Dimensions	60.0 mm x 22.0 mm x 3.58 mm (2.36" x 0.87" x 0.14")
	Weight	7 g (0.25 oz)
	Form Factor	M.2
	M.2 Type	2260-D2-B-M
Interface	Bus Interface	SATA III 6Gb/s
Storage	Flash Type	MLC NAND flash
	Capacity	32 GB/64 GB/128 GB/256 GB/512 GB
Operating Environment	Operating Voltage	3.3V±5%
	Operating Temperature	Standard: 0°C (32°F) ~ 70°C (158°F)
		Wide Temp.: -40°C (-40°F) ~ 85°C (185°F)
	Storage Temperature	-40°C (-40°F) ~ 85°C (185°F)
	Humidity	0% ~ 95%
	Shock	1500 G, 0.5 ms, 3 axis
Vibration	20 G (peak-to-peak), 7 Hz ~ 2000 Hz (frequency)	
Power	Power Consumption (Operation)	2.50 watt(s)
	Power Consumption (Sleep)	0.35watt(s)
Performance	Sequential Read/Write (CrystalDiskMark, max.)	Read: 530 MB/s; write: 450 MB/s
	4K Random Read/Write (IOmeter, max.)	Read: 70,000 IOPS; write: 70,000 IOPS
	Mean Time Between Failures (MTBF)	2,500,000 hour(s)
	Terabytes Written (Max.)	1,480 TBW
	Drive Writes Per Day (DWPD)	2.6 (3 yrs)
Warranty	Certificate	CE/FCC/BSMI
	Warranty	Three-year Limited Warranty
Note	<ul style="list-style-type: none"> <li>• Speed may vary due to host hardware, software, usage, and storage capacity.</li> <li>• The workload used to rate DWPD may be different from your actual workload, which may vary due to host hardware, software, usage, and storage capacity.</li> </ul>	

## Mechanical Dimensions

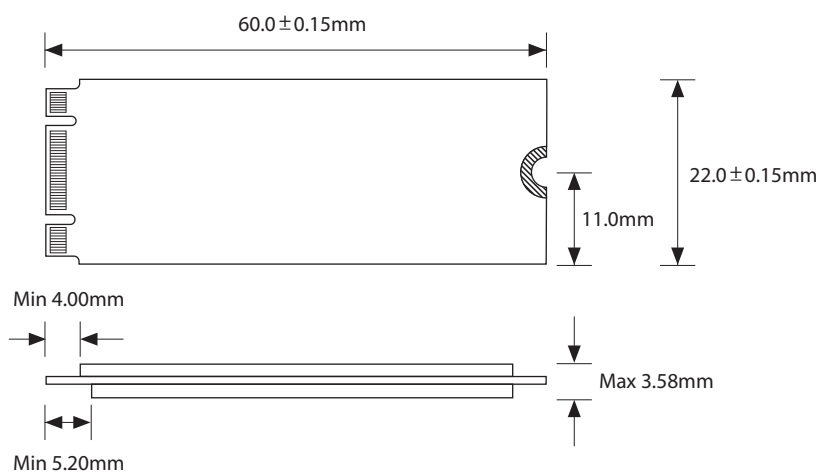

Product specifications are subject to change without notice. Pictures shown may differ from actual products. Total accessible capacity varies depending on operating environment. Due to the complexity and variety of industrial applications, Transcend cannot guarantee 100% compatibility with all platforms and under all scenarios. For special applications and environments, it is strongly suggested that you contact Transcend beforehand for clarification.



Please feel free to contact us with any special requests you might have.  
Tel: +886-2-2792-8000 [www.transcend-info.com](http://www.transcend-info.com)