

## Embedded Solutions

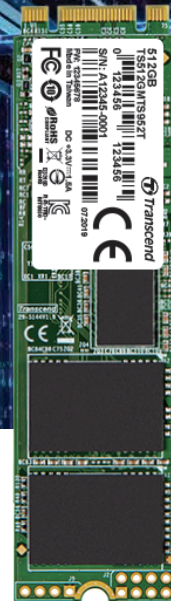

# SATA III M.2 SSDs MTS952T

3K P/E cycles

Transcend's MTS952T M.2 SSD features the SATA III 6Gb/s interface and state-of-the-art 3D NAND technology, which allows 96 layers of 3D NAND flash chips to be vertically stacked. Compared to BiCS3 NAND at 64 layers, this density breakthrough greatly improves storage efficiency. The MTS952T is built with DRAM cache for fast access, and is fully tested in-house to guarantee reliability in mission-critical applications, boasting an endurance rating of 3K Program/Erase cycles.

## Features

- DRAM Cache embedded
- Space-saving M.2 form factor (80mm) – ideal for mobile computing devices
- Endurance: 3K P/E cycles (Program/Erase cycles) guaranteed
- Advanced Global Wear-Leveling and Block management for reliability
- Advanced Garbage Collection
- Built-in LDPC ECC (Error Correction Code) functionality
- Enhanced S.M.A.R.T. function for durability
- Compliant with RoHS 2.0 standards
- Supports Trim and NCQ command
- Power-saving DevSleep (Device Sleep) mode (optional)

## Ordering Information

64GB	TS64GMTS952T
128GB	TS128GMTS952T
256GB	TS256GMTS952T
512GB	TS512GMTS952T
1TB	TS1TMTS952T
2TB	TS2TMTS952T

## Specifications

Appearance	Dimensions (Max.)	80 mm x 22 mm x 3.58 mm (3.15" x 0.87" x 0.14")
	Weight (Max.)	9 g (0.32 oz)
	Form Factor	M.2
	M.2 Type	2280-D2-B-M
Interface	Bus Interface	SATA III 6Gb/s
Storage	Flash Type	3D TLC NAND flash
	Capacity	64 GB/128 GB/256 GB/512 GB/1 TB/2 TB
Operating Environment	Operating Voltage	3.3V±5%
	Operating Temperature	0°C (32°F) ~ 70°C (158°F)
	Storage Temperature	-40°C (-40°F) ~ 85°C (185°F)
	Humidity	5% ~ 95%
	Shock	1500 G, 0.5 ms, 3 axis
	Vibration (Operating)	2.17 G (peak-to-peak), 10 Hz ~ 700 Hz (frequency)
Power	Power Consumption (Operation)	2.1 watt(s)
	Power Consumption (Sleep)	0.3 watt(s)
Performance	Sequential Read/Write (CrystalDiskMark, max.)	Read: 560 MB/s; write: 520 MB/s
	4K Random Read/Write (IOmeter, max.)	Read: 95,000 IOPS ; write: 85,000 IOPS
	Mean Time Between Failures (MTBF)	3,000,000 hour(s)
	Terabytes Written (Max.)	3,520 TB
	Drive Writes Per Day (DWPD)	1.61 (3 yrs)
Warranty	Certificate	CE/FCC/BSMI
	Warranty	Three-year Limited Warranty
Note	<ul style="list-style-type: none"> <li>• Speed may vary due to host hardware, software, usage, and storage capacity.</li> <li>• The workload used to rate DWPD may be different from your actual workload, which may vary due to host hardware, software, usage, and storage capacity.</li> </ul>	

## Mechanical Dimensions

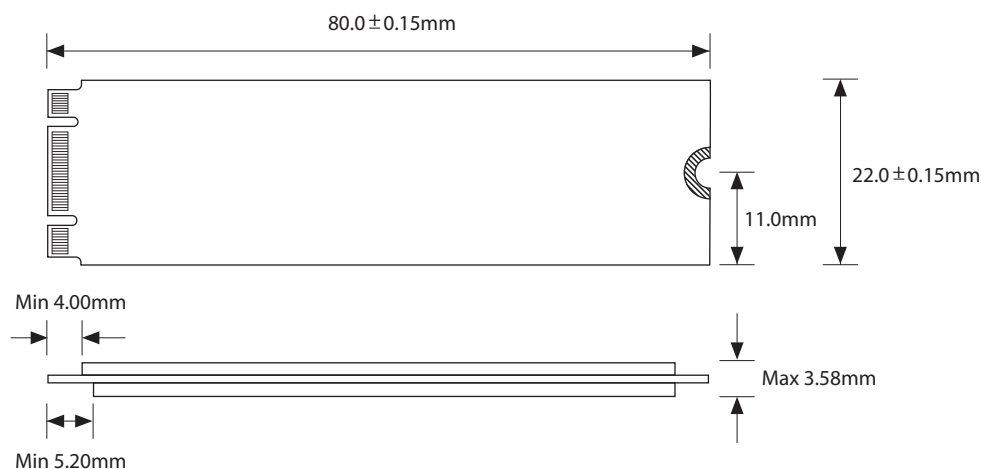

Product specifications are subject to change without notice. Pictures shown may differ from actual products. Total accessible capacity varies depending on operating environment. Due to the complexity and variety of industrial applications, Transcend cannot guarantee 100% compatibility with all platforms and under all scenarios. For special applications and environments, it is strongly suggested that you contact Transcend beforehand for clarification.



Please feel free to contact us with any special requests you might have.  
 Tel: +886-2-2792-8000 [www.transcend-info.com](http://www.transcend-info.com)