



Embedded Solutions



PCIe M.2 SSDs

MTE352T & MTE352T-I

Transcend's single-sided MTE352T M.2 SSD features the PCI Express (PCIe) Gen 3 x2 interface and is compatible with NVM Express (NVMe) 1.3 specifications to achieve never-before-seen transfer speeds. The MTE352T features state-of-the-art 3D NAND technology, which allows 96 layers of 3D NAND flash chips to be vertically stacked. Compared to 3D NAND at 64 layers, this density breakthrough greatly improves storage efficiency, and its built-in DRAM cache allows faster access. Applied with 30µ" gold finger PCB and Corner Bond technology, the MTE352T is fully tested in-house to guarantee reliability, boasting an endurance rating of 3K Program/Erase cycles. The MTE352T can be applied in an extended operating temperature ranging from -20°C~75°C as well as wide temperature ranging from -40°C ~ 85°C, ensuring sustained functionality in mission critical applications.

Hardware Features

- Key components fortified by default with Corner Bond technology
- PCIe Gen 3 x2 interface
- Endurance: 3K P/E cycles (Program/Erase cycles) guaranteed
- 30µ" PCB gold finger
- Extended Temp. (-20°C ~ 75°C) and Wide Temp. (-40°C ~ 85°C) options available

Ordering Information

128GB	TS128GMTE352T TS128GMTE352T-I
256GB	TS256GMTE352T TS256GMTE352T-I
512GB	TS512GMTE352T TS512GMTE352T-I

Firmware Features

- SLC caching technology
- Supports NVM command
- Built-in LDPC ECC (Error Correction Code) functionality
- Advanced Garbage Collection
- Dynamic thermal throttling

Specifications

Appearance	Dimensions	30 mm x 22 mm x 2.38 mm (1.18" x 0.87" x 0.08")
	Weight	4 g (0.14 oz)
	Form Factor	M.2
	M.2 Type	2230-S3-B-M (Single-sided)
Interface	Bus Interface	NVMe PCIe Gen3 x2
Storage	Flash Type	3D NAND flash
	Capacity	128 GB / 256 GB / 512 GB
Operating Environment	Operating Voltage	3.3V±5%
	Operating Temperature	Extended -20°C (-4°F) ~ 75°C (167°F)
		Wide Temp. -40°C (-40°F) ~ 85°C (185°F)
	Storage Temperature	-55°C (-67°F) ~ 85°C (185°F)
	Humidity	5% ~ 95%
	Shock	1500 G, 0.5 ms, 3 axis
	Vibration (Operating)	20 G (peak-to-peak), 7 Hz ~ 2000 Hz (frequency)
Power	Power Consumption (Operation)	3.12 watt(s)
	Power Consumption (IDLE)	0.36 watt(s)
Performance	Sequential Read/Write (CrystalDiskMark, max.)	Read: up to 1,700 MB/s Write: up to 1,000 MB/s
	4K Random Read/Write (IOMeter, max.)	Read: up to 150,000 IOPS Write: up to 230,000 IOPS
	Mean Time Between Failures (MTBF)	3,000,000 hour(s)
	Terabytes Written (Max.)	1,080 TBW
	Drive Writes Per Day (DWPD)	2.0 (3 yrs)
Warranty	Certificate	CE / FCC / BSMI
	Warranty	Three-year Limited Warranty

Mechanical Dimensions

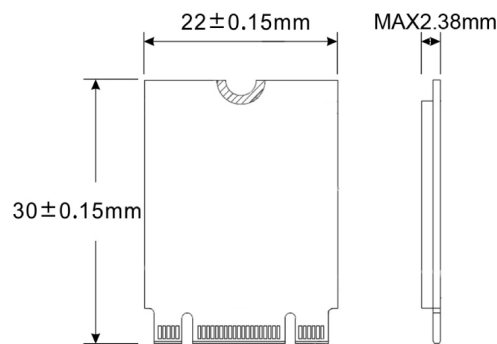

Product specifications are subject to change without notice. Pictures shown may differ from actual products. Total accessible capacity varies depending on operating environment. Due to the complexity and variety of industrial applications, Transcend cannot guarantee 100% compatibility with all platforms and under all scenarios. For special applications and environments, it is strongly suggested that you contact Transcend beforehand for clarification.