

## Embedded Solutions



### PCIe M.2 SSDs

# MTE652T & MTE652T-I

3K P/E cycles

Transcend's MTE652T M.2 SSD features the PCI Express (PCIe) Gen 3 x4 interface and is compatible with NVMe Express (NVMe) 1.3 specifications to achieve never-before-seen transfer speeds. The MTE652T features state-of-the-art 3D NAND technology, which allows 96 layers of 3D NAND flash chips to be vertically stacked. Compared to 3D NAND at 64 layers, this density breakthrough greatly improves storage efficiency. The MTE652T is built with DRAM cache for fast access, and is fully tested in-house to guarantee reliability in mission-critical applications, boasting an endurance rating of 3K Program/Erase cycles.

Transcend also offers the MTE652T-I with wide temperature (-40°C ~ 85°C) capabilities to ensure sustained functionality, enhanced endurance and optimal reliability in mission-critical applications.

## Features

- DRAM Cache embedded
- Endurance: 3K P/E cycles (Program/Erase cycles) guaranteed
- Wide-temperature model available: promised operational reliability in a wide temperature range (from -40°C to 85°C)
- PCIe Gen 3 x4 interface
- Compliant with PCI Express specification 3.1
- Compliant with NVMe Express specification 1.3
- Supports NVMe command
- SLC caching technology
- Built-in LDPC ECC (Error Correction Code) functionality
- Dynamic thermal throttling
- Compliant with RoHS 2.0 standards
- Supports Transcend SSD Scope Pro software

## Ordering Information

### Standard (0°C~ 70°C)

|       |               |
|-------|---------------|
| 128GB | TS128GMTE652T |
| 256GB | TS256GMTE652T |
| 512GB | TS512GMTE652T |

### Wide Temp. (-40°C~ 85°C)

|       |                 |
|-------|-----------------|
| 128GB | TS128GMTE652T-I |
| 256GB | TS256GMTE652T-I |
| 512GB | TS512GMTE652T-I |

## Specifications

|                       |   |   |
|-----------------------|---|---|
| Appearance            | Dimensions  | 80 mm x 22 mm x 3.58 mm (3.15" x 0.87" x 0.14") |
|                       | Weight  | 9 g (0.32 oz)                                   |
|                       | Form Factor   | M.2   |
|                       | M.2 Type  | 2280-D2-M (Double-sided)                        |
| Interface             | Bus Interface   | NVMe PCIe Gen3 x4                               |
| Storage               | Flash Type  | 3D NAND flash                                   |
|                       | Capacity  | 128 GB/256 GB/512 GB                            |
| Operating Environment | Operating Voltage   | 3.3V±5%   |
|                       | Operating Temperature   | Standard: 0°C (32°F) ~ 70°C (158°F)             |
|                       |   | Wide Temp.: -40°C (-40°F) ~ 85°C (185°F)        |
|                       | Storage Temperature   | -40°C (-40°F) ~ 85°C (185°F)                    |
|                       | Humidity  | 5% ~ 95%  |
|                       | Shock   | 1500 G, 0.5 ms, 3 axis                          |
| Vibration             | 20G (peak-to-peak), 7 Hz ~ 2000 Hz (frequency)  |   |
| Power                 | Power Consumption (Operation)   | 3.3 watt(s)                                     |
|                       | Power Consumption (IDLE)  | 0.6 watt(s)                                     |
| Performance           | Sequential Read/Write (CrystalDiskMark, max.)   | Read: 2,100 MB/s ; write: 1,250 MB/s            |
|                       | 4K Random Read/Write (IOMeter, max.)  | Read: 190,000 IOPS ; write: 290,000 IOPS        |
|                       | Mean Time Between Failures (MTBF)   | 3,000,000 hour(s)                               |
|                       | Terabytes Written (Max.)  | 1,080 TBW                                       |
|                       | Drive Writes Per Day (DWPD)   | 2 (3 yrs)                                       |
| Warranty              | Certificate   | CE/FCC/BSMI                                     |
|                       | Warranty  | Three-year Limited Warranty                     |
| Note                  | <ul style="list-style-type: none"> <li>• Speed may vary due to host hardware, software, usage, and storage capacity.</li> <li>• The workload used to rate DWPD may be different from your actual workload, which may vary due to host hardware, software, usage, and storage capacity.</li> </ul> |   |

## Mechanical Dimensions

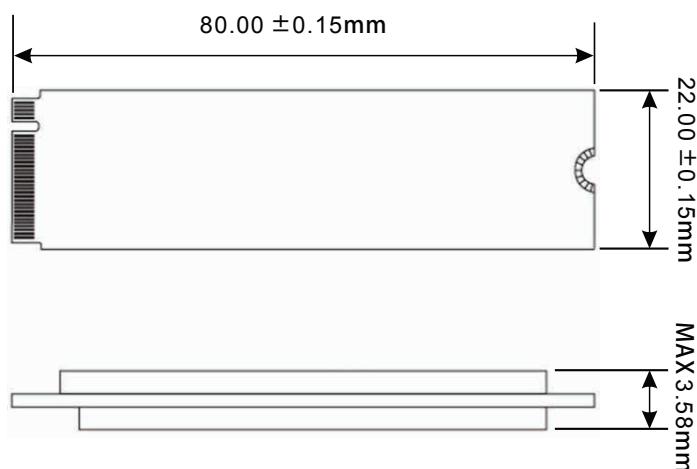

Product specifications are subject to change without notice. Pictures shown may differ from actual products. Total accessible capacity varies depending on operating environment. Due to the complexity and variety of industrial applications, Transcend cannot guarantee 100% compatibility with all platforms and under all scenarios. For special applications and environments, it is strongly suggested that you contact Transcend beforehand for clarification.



Please feel free to contact us with any special requests you might have.  
Tel: +886-2-2792-8000 [www.transcend-info.com](http://www.transcend-info.com)