

Embedded Solutions

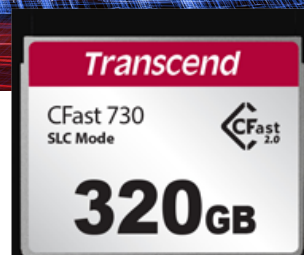

CFast Cards

CFX730 & CFX730I

Transcend's CFX730 CFast card is designed with 112-layer 3D NAND flash and SATA III 6Gb/s interface, featuring high transfer speeds and large capacities, as well as plug-and-play convenience. The CFX730 can operate stably under $-5^{\circ}\text{C} \sim 70^{\circ}\text{C}$, and wide-temperature ($-40^{\circ}\text{C} \sim 85^{\circ}\text{C}$) model can be provided upon request. The CFX730 comes with SLC Mode technology, enhancing flash endurance to 100K P/E cycles while having a sustained write speed that is suitable for write-intensive equipment.

Hardware Features

- Compliant with RoHS 2.0 standards
- Compliant with CFast specification 2.0
- High-quality 3D NAND flash and SLC mode for exceptional endurance and reliability
- Promised operational reliability in a wide temperature range (from -40°C to 85°C)
- Durability: 10,000 insertion/removal cycles

Firmware Features

- Built-in LDPC ECC (Error Correction Code) functionality
- Advanced Global Wear-Leveling and Block management for reliability
- Supports S.M.A.R.T. function to conduct health monitoring, analysis, and reporting for storage devices
- Power-saving DevSleep (Device Sleep) mode
- NCQ command for better performance

Ordering Information

20GB	TS20GCFX730 TS20GCFX730I
40GB	TS40GCFX730 TS40GCFX730I
80GB	TS80GCFX730 TS80GCFX730I
160GB	TS160GCFX730 TS160GCFX730I
320GB	TS320GCFX730 TS320GCFX730I

Specifications

Appearance	Dimensions	42.8 mm x 36.4 mm x 3.3 mm (1.69" x 1.43" x 0.13")
	Form Factor	CFast
Interface	Bus Interface	SATA III 6Gb/s
Storage	Flash Type	112-layer 3D NAND flash (SLC mode)
	Capacity	20 GB / 40 GB / 80 GB / 160 GB / 320 GB
Operating Environment	Operating Voltage	3.3V±5%
	Operating Temperature	Standard Temp. -5°C (23°F) ~ 70°C (158°F)
		Wide Temp. -40°C (-40°F) ~ 85°C (185°F)
	Storage Temperature	-40°C (-40°F) ~ 85°C (185°F)
	Humidity	0% ~ 95%
	Shock	1500 G, 0.5 ms, 3 axis
Vibration (Operating)	3 G (peak-to-peak), 5 Hz ~ 800 Hz (frequency)	
Power	Power Consumption (Max.)	1.2 watt(s)
Performance	Read Speed (Max.)	Up to 550 MB/s
	Write Speed (Max.)	Up to 520 MB/s
	Mean Time Between Failures (MTBF)	3,000,000 hour(s)
Warranty	Warranty	Three-year Limited Warranty

Mechanical Dimensions

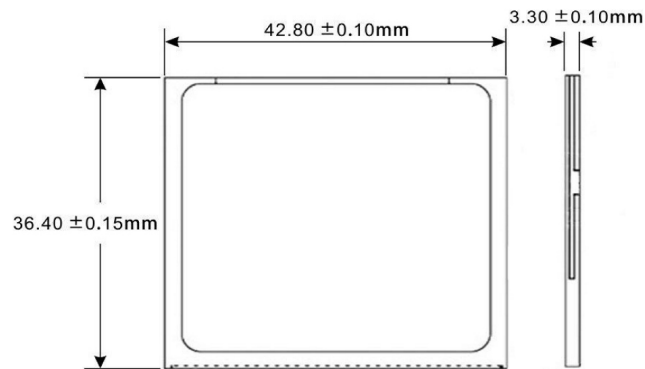

Product specifications are subject to change without notice. Pictures shown may differ from actual products. Total accessible capacity varies depending on operating environment. Due to the complexity and variety of industrial applications, Transcend cannot guarantee 100% compatibility with all platforms and under all scenarios. For special applications and environments, it is strongly suggested that you contact Transcend beforehand for clarification.